

B

Basic Pump



Self Priming Centrifugal Pump

Model RS2A31-B and RS2A32-B

Size 3" x 2"

PUMP SPECIFICATIONS

Size: 3" x 2" (76 mm x 51 mm) Flanged.

Casing: (RS2A31-B) Ductile Iron No. 65-45-12.
(RS2A32-B) Cast Steel 70-36.

Maximum Operating Pressure 48 PSI (331 kPa).*

Enclosed Type, Four Vanes Impeller: Aluminum 356-T6.
Handles 1/4" (6,4 mm) Diameter Spherical Solids.

Impeller Shaft: Steel No. 1045.

Rotor: Copper Alloy C93200.

Bearing Housing: Ductile Iron No. 65-45-12.

Bearing Housing Lubrication: Grease.

Body Cover: (RS2A31-B) Ductile Iron No. 65-45-12.
(RS2A32-B) Cast Steel 70-36.

Center/Spacer Plate: (RS2A31-B) Ductile Iron No. 65-45-12.
(RS2A32-B) Cast Steel 70-36.

Radial Bearing: Permanently Sealed Single Row Ball Type.

Thrust Bearing: Permanently Sealed Single Row Ball Type.

Gaskets: Vegetable Fiber, PTFE and Cork.

Priming: Rotary Vane Type with Built-in Spring-Loaded Priming Assist Valve.

Optional Equipment: Cast Steel 70-36 Threaded Suction and Discharge Companion Flange Kit, Copper Alloy C93700 Impeller, Group Grind with Cast Iron Rotor (RS2A31-B Only), Stainless Steel No. 416 Impeller Shaft, Buna-N Seal, PTFE Seal with Viton O-Ring, PTFE Seal with Buna-N O-Ring, Oil Filled Bearing Housing Assembly.

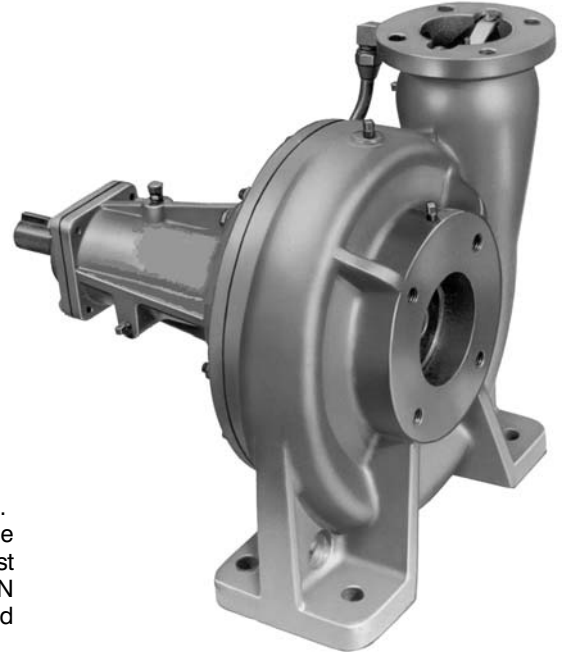

*Consult Factory for Applications Exceeding Maximum Pressure and/or Temperature Indicated.

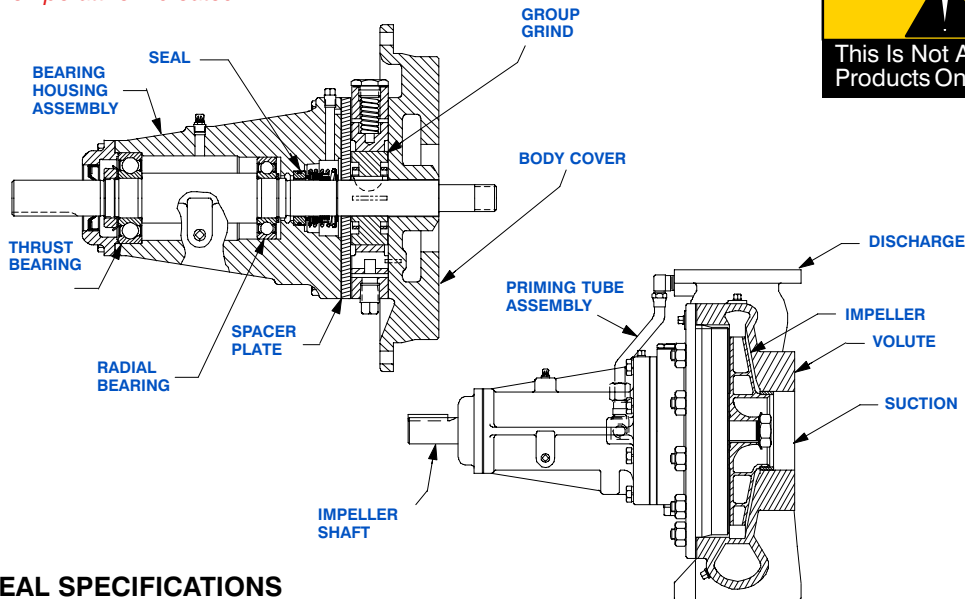

SEAL AREA DETAIL

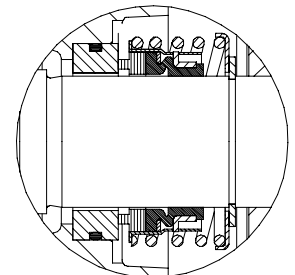

SEAL SPECIFICATIONS

Seal: Mechanical; Self-Lubricated. Fluorocarbon Elastomers (DuPont Viton® or Equivalent). Carbon Rotating Face; Ni-Resist Stationary Face; Maximum Temperature of Liquid Pumped is 160°F (71°C).*



THE GORMAN-RUPP COMPANY • MANSFIELD, OHIO

GORMAN-RUPP OF CANADA LIMITED • ST. THOMAS, ONTARIO, CANADA

www.grpumps.com

Specifications Subject to Change Without Notice

Printed in U.S.A.

Specification Data

SECTION 35, PAGE 100

OVERALL DIMENSIONS
and
APPROXIMATE WEIGHTS

RS2A31-B

RS2A32-B

PUMP NET WEIGHT: 159 LBS. (72,1 KG.) 158 LBS. (71,7 KG.)
SHIPPING NET WEIGHT: 169 LBS. (76,7 KG.) 168 LBS. (76,2 KG.)
EXPORT CRATE SIZE: 8.1 CU. FT. (0,23 CU. M.)

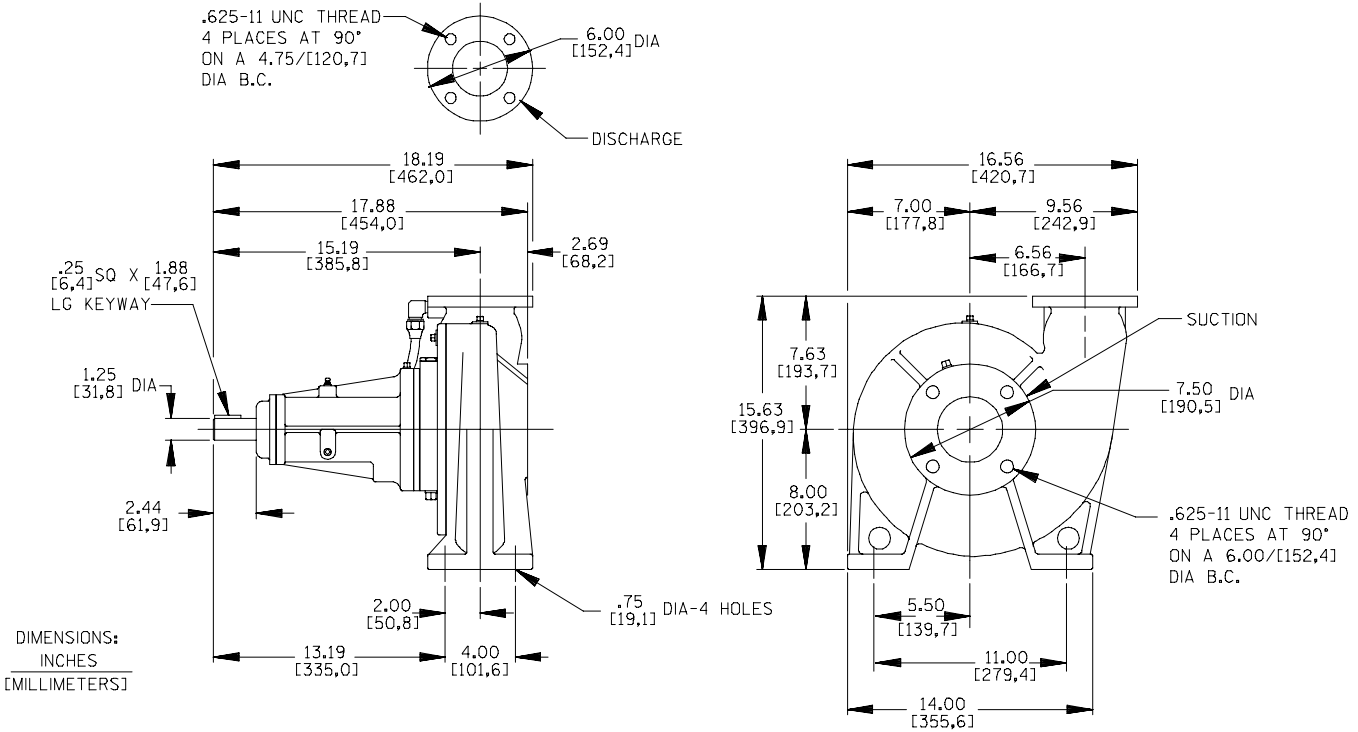

Air Release Valve Required When Static Discharge Pressure Exceeds 8 psi (55 kPa).

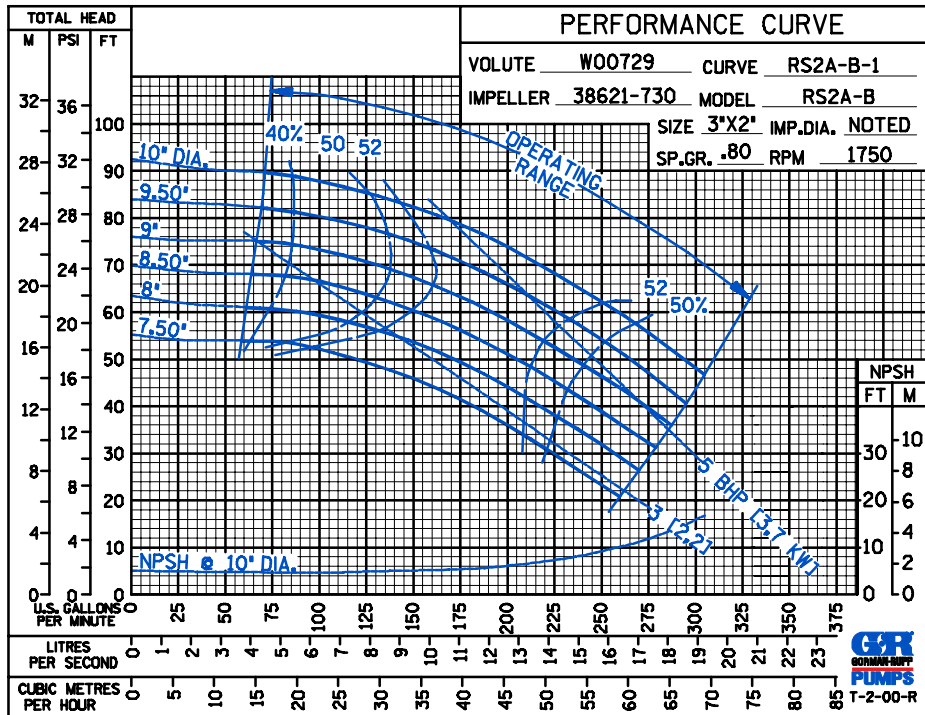

THE GORMAN-RUPP COMPANY • MANSFIELD, OHIO

GORMAN-RUPP OF CANADA LIMITED • ST. THOMAS, ONTARIO, CANADA

Specifications Subject to Change Without Notice

Printed in U.S.A.